



## Series 1716

Tour & Andersson  
DZR Brass  
Tested Gate Valve  
c/w DZR Brass Key Cap

### FEATURES

MANUFACTURED IN SWEDEN

WATERMARKED TO AS 1628 LICENCE WMKA00772

FULL BORE

SUITABLE FOR USE WITH DIESEL

INTERNAL GUIDES ENSURE PROPER CLOSURE OF GATE

DZR BRASS KEY CAP FOR UNDERGROUND INSTALLATIONS

PRECOMPRESSED PTFE GLAND PACKING

MUST BE OPERATED IN FULLY OPEN OR CLOSED POSITION

ALL VALVES PRESSURE TESTED DURING PRODUCTION

SIZE RANGE: 40MM TO 50MM

### PRESSURE AND TEMPERATURE RATINGS

TEMPERATURE RANGE: -10°C TO 99°C

MAXIMUM OPERATING PRESSURE AT NOMINAL TEMPERATURES: 2500 kPa



**WaterMark**

LN WMKA00772  
AS 1628

# Series 1716

Tour & Andersson DZR Brass

Tested Gate Valve c/w DZR Brass Key Cap



## DIMENSIONAL AND COMPONENT DIAGRAM

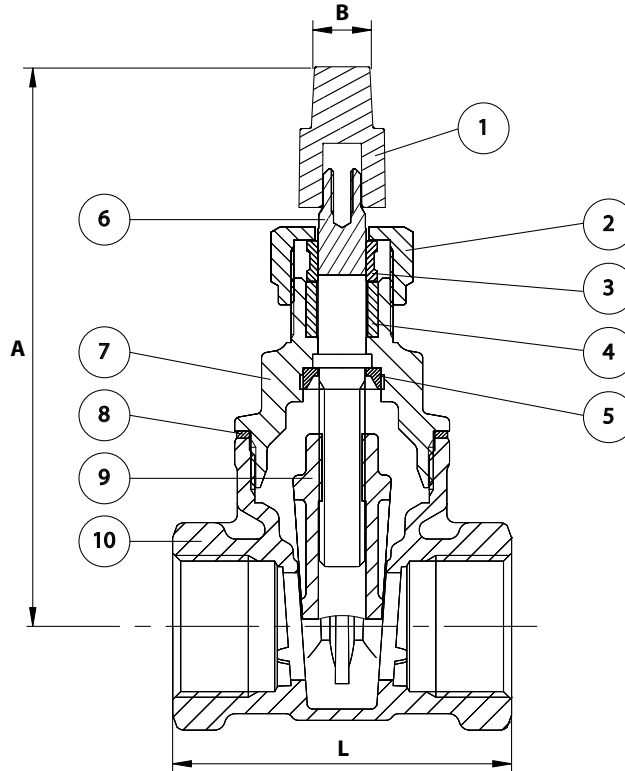

### MATERIALS

POS.	PART NAME	MATERIALS
1	KEY CAP	DZR BRASS
2	GLAND NUT	DZR BRASS
3	GLAND	DZR BRASS
4	PACKING	PTFE + CARBON
5	LOCK RING	DZR BRASS
6	STEM	DZR BRASS
7	BONNET	DZR BRASS
8	GASKET	VULCANISED FIBRE
9	WEDGE	DZR BRASS
10	BODY	DZR BRASS

### DIMENSIONS - mm

Prod. Code	Size	A	B	L	Kv	Wgt kg
1716040	40	152.5	11.24	86	150	1.16
1716050	50	167.5	11.24	99	270	2.32