



Series 1712

Zetco Bronze
Outside Screw & Yoke
Bolted Bonnet
Gate Valve Flanged

FEATURES

MANUFACTURED IN ITALY

FULL BORE

INTEGRAL SEAT

CAST IRON HANDWHEEL

FLANGES ARE DRILLED TO CLIENT SPECIFICATIONS

MUST BE OPERATED IN FULLY OPEN OR CLOSED POSITION

ALL VALVES PRESSURE TESTED DURING PRODUCTION

SIZE RANGE: 40MM TO 50MM, 80MM TO 250MM

PRESSURE AND TEMPERATURE RATINGS

TEMPERATURE RANGE: -10°C TO 99°C

MAXIMUM OPERATING PRESSURE AT NOMINAL TEMPERATURES: 1600 kPa

FOR RATINGS AT SPECIFIC TEMPERATURES REFER TO GRAPH OVERLEAF



Series 1712

Zetco Bronze Outside Screw & Yoke
Bolted Bonnet Gate Valve Flanged

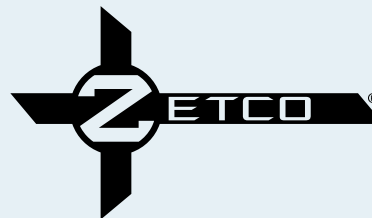

DIMENSIONAL AND COMPONENT DIAGRAM

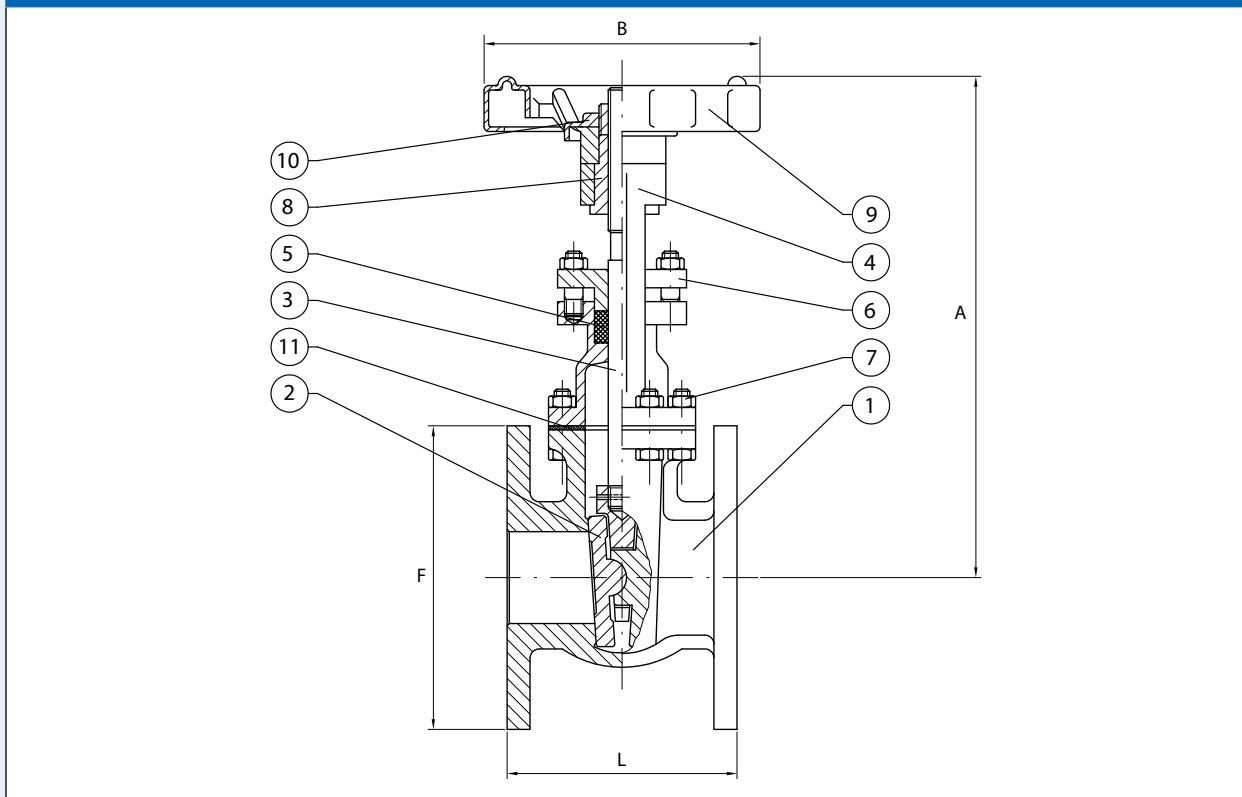

MATERIALS

POS.	PART NAME	MATERIALS
1	BODY	BRONZE
2	WEDGE	BRONZE
3	STEM	BRONZE
4	BONNET	BRONZE
5	PACKING	PTFE
6	PACKING GLAND	BRONZE
7	BOLT	STAINLESS STEEL 304
8	GLAND NUT	BRASS
9	HAND WHEEL	CAST IRON
10	NUT	BRASS
11	GASKET	FIBRE

DIMENSIONS - mm

Prod. Code	Size	A	B	L	F	Kv	Wgt kg
1712040	40	270	125	165	127	140	8.00
1712050	50	320	125	178	152	220	10.14
1712080	80	420	200	203	190	560	23.50
1712100	100	500	200	229	229	880	30.00
1712150	150	700	300	267	280	2300	55.00
1712200	200	900	350	292	343	4090	90.00
1712250	250	1385	400	330	406.4	6390	270.0

PRESSURE/TEMPERATURE DIAGRAM

